

MAXA[®]
AIR CONDITIONING



CE

Air/water inverter heat pumps with axial fans

Manual Troubleshooting

Models

I-290 0121

I-290 0123

I-290 0125

I-290 0127



www.maxa.it

f in



This manual has been created for informational purposes. The company declines all responsibility for the results of a design or installation based on the explanations and technical specifications given in this manual. It is also forbidden to reproduce, even partially, in any form whatsoever, the texts and figures contained in this manual. The data contained in this manual are not binding and may be changed by the manufacturer without prior notice. Manual in the original language. Reproduction, even partial, © FORBIDDEN Copyright - Advantix SpA

An
Italian
Company

i-290 0121-0127 TROUBLESHOOTING

01	31-10-2024	AA	MS	Alignment to V415R024S18 firmware
00	14-03-2024	AA	MS	First issue
Rev	Date	Drafted	Approved	Notes
Catalogue				Series
MTR02060120000_01				i-290 0121-0127 TROUBLESHOOTING

ELECTRICAL PANEL EDGE CONNECTORS

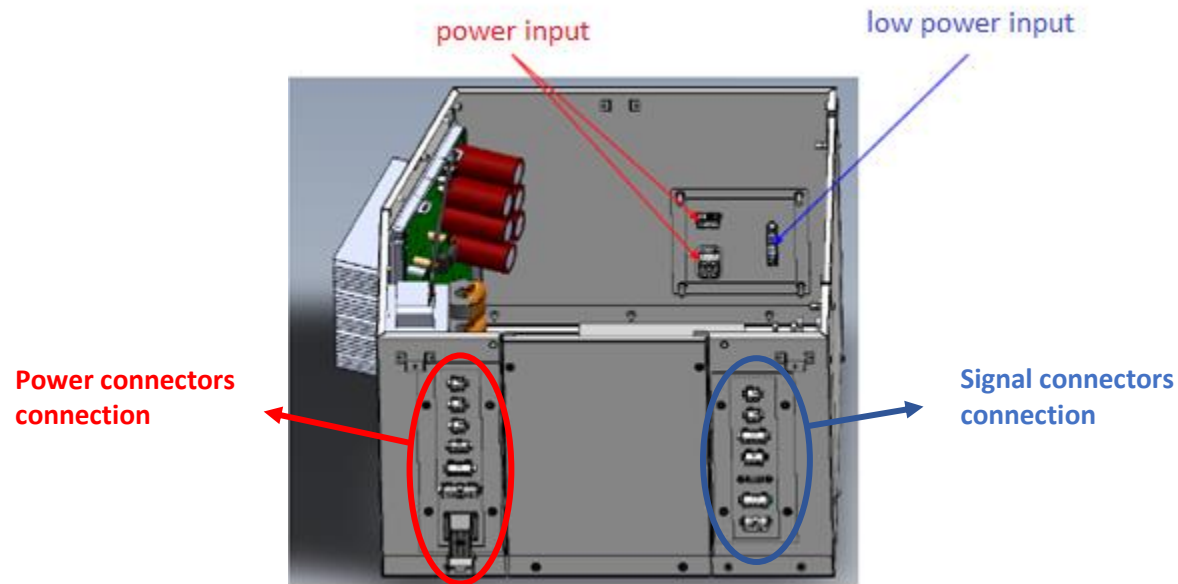

CONNECTIONS BETWEEN ELECTRICAL PANEL AND ON-BOARD UNIT ELEMENTS

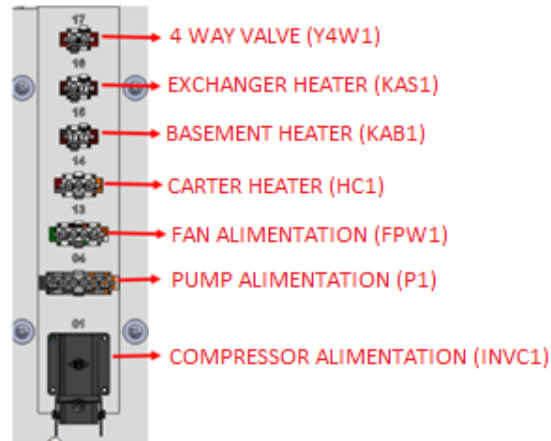

RIF. COMPONENTE	RIF. CONNETTORE SCHEMA ELETTRICO	NUMERAZIONE SU BORDO MACCHINA
Y4W1	CNY4W-	17
KAS1	CNKAS-	16
KAB1	CNKAB-	15
HC1	CNHC-	14
FPW1	CNFPW-	13
P1	CNP-	04
INVC1	CNC-	01

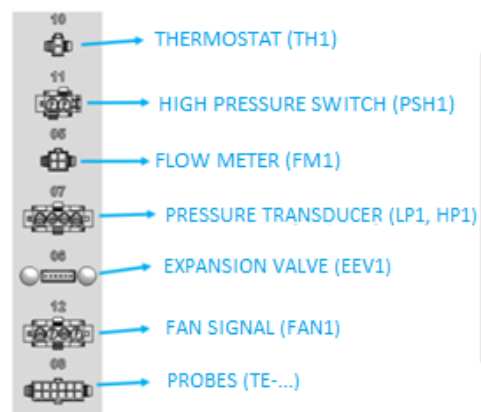

RIF. COMPONENTE	RIF. CONNETTORE SCHEMA ELETTRICO	NUMERAZIONE SU BORDO MACCHINA
TH1	CNTH-	10
PSH1	CNPSH-	11
FM1	CNFM-	05
LP1, HP1	CNTR-	07
EEV1	CNE-	06
FAN1	CNFS-	12
TE-INV1 TE-OUT1 TE-SD1 TE-DT1 TE-EXT1	CNTP-	08

INSTALLER TERMINAL BLOCK

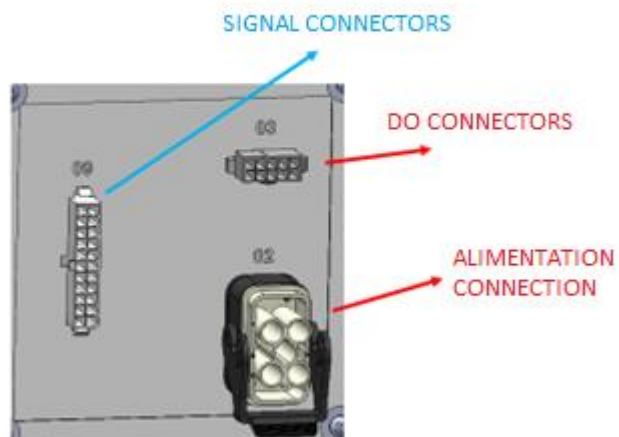

CONNETTORE	RIF. SCHEMA ELETTRICO	NUMERAZIONE SU BORDO MACCHINA
ALIMENTAZIONE	CNPW-	02
SEGNALI	CNSG-	09
DO	CNDO-	03

i-290 0121-0127 TROUBLESHOOTING

Code	Description	Block	Cause	What to check	What to do
E002	Low pressure alarm	MACHINE	<p>The pressure transducer detects a pressure lower than "low pressure set". Low Pressure Cooling=2bar Low pressure set in heating=0.3bar</p> <p>Retracts when the pressure rises above 4bar in cooling and 2.3bar in heating</p> <p>If the alarm occurs more than 3 times per hour, the reset becomes manual</p>	<ul style="list-style-type: none"> • Check for gas leaks in the refrigerant circuit (leakage detector, ...) • Check that the low pressure transducer reading is correct by placing a pressure gauge on the low pressure charging connection, for the position see chapter 5.9 of the user-installer manual • If the alarm shows up in cooling mode, check that the EEV valve is working properly • Check the fixing and operation of the EEV thermostatic valve, physically verifying that the change in the valve steps displayed on the scada corresponds to an actual movement of the valve • If the alarm is in heating mode, check that the fan is working correctly • Check that the gas charge complies with the technical label on board the unit 	<ul style="list-style-type: none"> • If leaks have been detected: Recover the remaining refrigerant, repair the leak if possible and restore the charge by checking the data in the technical label • If the gauge reading does not match the reading given by the low pressure transducer, replace the low pressure transducer • If the EEV valve malfunction has occurred, replace the coil. If the error persists, replace the valve body <p>Make sure that the valve tube is not plugged by placing the magnet on the valve and checking the effect it has on the E002 error. If the error persists, the hose is plugged. If the error disappears, replace the EEV coil</p> <ul style="list-style-type: none"> • If the gas charge does not comply with the technical label, drain all the gas and refill the correct amount
E005	Frost alarm	MACHINE	<p>If the supply water probe (TE OUT1) has a value lower than A08 (default 3°C) This alarm is manual reset.</p> <p>In cooling mode the alarm is immediate while in heating mode it is active after 2 min. The alarm resets when the temperature returns to a value above 6°C</p>	<ul style="list-style-type: none"> • The temperature probe is correctly inserted into the outlet water probe housing • Check the temperature at the outlet probe with a reference thermometer • If the error occurs only in cooling mode, check that the direction of rotation of the circulator is correct. 	<ul style="list-style-type: none"> • If the probe is not properly inserted into the probe housing, insert it • If the temperature measured by the reference thermometer is different from the temperature measured by the supply probe, the probe is defective; replace it <ul style="list-style-type: none"> • If the direction of the circulator is incorrect, turn it

i-290 0121-0127 TROUBLESHOOTING

Code	Description	Block	Cause	What to check	What to do
E006	Flow alarm	MACHINE	<p>If the flowmeter diagnoses a lack of flow for a consecutive time of 5 seconds. If the alarm occurs more than 3 times per hour, the reset becomes manual</p> <p>In the event of a flow error, the pump goes to the post-pumping phase (lasting P02 default 2 minutes). If during this phase the flow returns for a time of 5 seconds, then the alarm returns automatically, but this only if the number of interventions/hour of the alarm is not greater than 3.</p>	<ul style="list-style-type: none"> • Check the system pressure • Checking the operation of the flowmeter, checking the wiring of connector 5 (CNFM) <div data-bbox="1061 416 1240 794" data-label="Diagram"> </div> • Check the correct installation of the water inlet and outlet hoses on the machine <ul style="list-style-type: none"> • Check the status of the system water filters 	<ul style="list-style-type: none"> • If air is present in the hydraulic circuit, vent the system by performing the function. <p>With the machine in OFF, once the installer password has been entered, enter the force menu (FOR) and then choose SFIA. The system vent function is activated, which consists of activating the pump for use for 5 minutes. During this phase, the pump alternates maximum and minimum speed cycles lasting 1 minute. Pressing SFIA again can interrupt the procedure. The pump eventually performs a post-pumping of P02 (default 2 minutes).</p> <ul style="list-style-type: none"> • If the problem persists, replace the flow meter

i-290 0121-0127 TROUBLESHOOTING

Code	Description	Block	Cause	What to check	What to do
E009	High temperature alarm	COMPRESSOR OR	<p>If the discharge temperature associated with the compressor exceeds 110°C for at least 30 seconds, the alarm will be activated and the compressor will be blocked.</p> <p>If the temperature exceeds 120°C, the error is triggered without waiting for the bypass time.</p> <p>The alarm automatically returns when the discharge temperature drops below the 100°C threshold again.</p>	<ul style="list-style-type: none"> Check the wiring of the TE DT1 drain probe, and that the bulb is correctly inserted into the thermopaste well Check the connection of connector no8 Checking correct fan operation Check refrigerant charge 	<ul style="list-style-type: none"> If the probe is not properly positioned, correct
E010	High Temperature Solar Collector	SOLAR PUMP	<p>If the collector probe exceeds the value of the S12 parameter (maximum domestic solar storage tank temperature threshold), there is an alarm condition blocking the solar pump.</p> <p>The hysteresis of re-entry from the alarm condition is given by S08.</p> <p>This alarm is also triggered in the event of a failed solar collector probe.</p>	<ul style="list-style-type: none"> Check the integrity of the solar collector probe If the probe has no defects, check the measured temperature by comparing it to another probe on the same spot 	<ul style="list-style-type: none"> If the probe is not intact, replace it If the probe does not measure a correct temperature, replace it

i-290 0121-0127 TROUBLESHOOTING

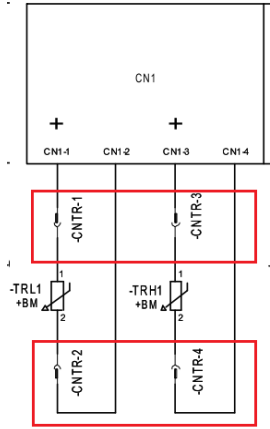
Code	Description	Block	Cause	What to check	What to do
E018	High temperature alarm in cooling	MACHINE	If the control probe has a value higher than 48°C for a time longer than 50 seconds, the alarm is active. Deactivation occurs if the temperature is below 45°C	<ul style="list-style-type: none"> • Check for proper coil wiring to the 4-way valve • Check for correct switching of the 4-way valve • Verify that the installation rules described in the MUI manual have been followed 	<ul style="list-style-type: none"> • If the 4-way valve is not working properly, replace the coil
E020	Inverted pressure transducer alarm	MACHINE	When compressors have been running for more than 150 seconds, if the suction pressure probe measures a pressure higher than the condensing pressure probe, then alarm E020 is reported. This alarm cannot be reset (the machine must be turned off to eliminate the alarm).	<ul style="list-style-type: none"> • Verification of correct positioning and wiring of low and high transducers on connector n°7 (CNTR)  <p>The diagram shows a connector labeled CN1 with four terminals: CN1-1, CN1-2, CN1-3, and CN1-4. Below the connector, there are four transducers: -CNTR-1 and -CNTR-3 are connected to CN1-1 and CN1-3 respectively, while -CNTR-2 and -CNTR-4 are connected to CN1-2 and CN1-4 respectively. The transducers are arranged in two columns. To the left of the first column, there is a terminal labeled -TRL1 +BM with a 'J' symbol. To the right of the second column, there is a terminal labeled -TRH1 +BM with a 'J' symbol. Red boxes highlight the connections for -CNTR-1 and -CNTR-3, and another red box highlights the connections for -CNTR-2 and -CNTR-4.</p>	<ul style="list-style-type: none"> • If the connector does not respect the positions shown in the diagram, replace it

i-290 0121-0127 TROUBLESHOOTING

Code	Description	Block	Cause	What to check	What to do																												
E611 E621 E631 E641 E651 E661 E671	Temperature probe failure	E611:E651 (MACHINE) E661, E671, E681 (ASSOCIATE D FUNCTION)	E6X1 The probe connected to the STX input is faulty, or connector No. 8 is not properly connected.	<ul style="list-style-type: none"> Verify the integrity of the probes Check the correct connection of connector n°8 	<ul style="list-style-type: none"> If the probes have defects, replace the CNTP connector 																												
			<table border="1"> <thead> <tr> <th>C. n°</th> <th>PIN</th> <th>Denom.</th> </tr> </thead> <tbody> <tr> <td rowspan="8">CN2</td> <td>1</td> <td rowspan="2">ST1</td> </tr> <tr> <td>2</td> </tr> <tr> <td>3</td> <td rowspan="2">ST2</td> </tr> <tr> <td>4</td> </tr> <tr> <td>5</td> <td rowspan="2">ST3</td> </tr> <tr> <td>6</td> </tr> <tr> <td>7</td> <td rowspan="2">ST4</td> </tr> <tr> <td>8</td> </tr> <tr> <td rowspan="6">CN3</td> <td>1</td> <td>ST5</td> </tr> <tr> <td>2</td> <td></td> </tr> <tr> <td>3</td> <td>/</td> </tr> <tr> <td>4</td> <td>/</td> </tr> <tr> <td>5</td> <td>/</td> </tr> <tr> <td>6</td> <td>/</td> </tr> </tbody> </table>	C. n°	PIN	Denom.	CN2	1	ST1	2	3	ST2	4	5	ST3	6	7	ST4	8	CN3	1	ST5	2		3	/	4	/	5	/	6	/	
			C. n°	PIN	Denom.																												
			CN2	1	ST1																												
				2																													
				3	ST2																												
				4																													
				5	ST3																												
				6																													
				7	ST4																												
8																																	
CN3	1	ST5																															
	2																																
	3	/																															
	4	/																															
	5	/																															
	6	/																															

i-290 0121-0127 TROUBLESHOOTING

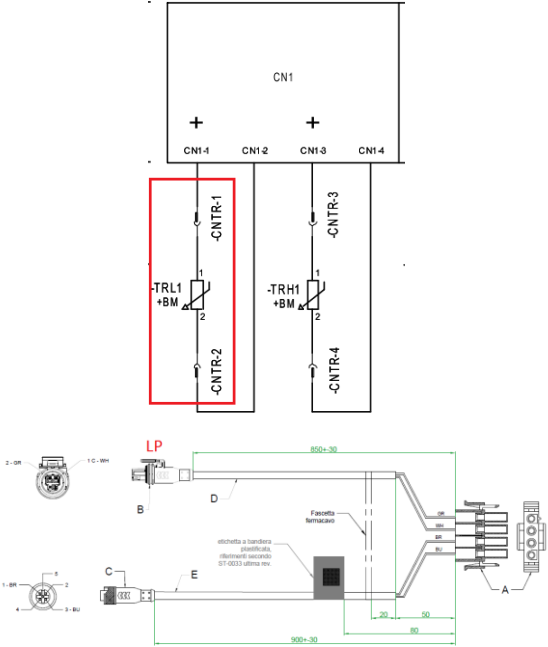
Code	Description	Block	Cause	What to check	What to do
E691	Low pressure transducer fault		Transducer connected to ST9 input not connected or faulty	<ul style="list-style-type: none"> Check that the LP1 transducer is connected to connector 7 at pins 1 and 2 	<ul style="list-style-type: none"> If the connector is properly connected, the transducer may be defective. Replace with a new No. 7 connector

i-290 0121-0127 TROUBLESHOOTING

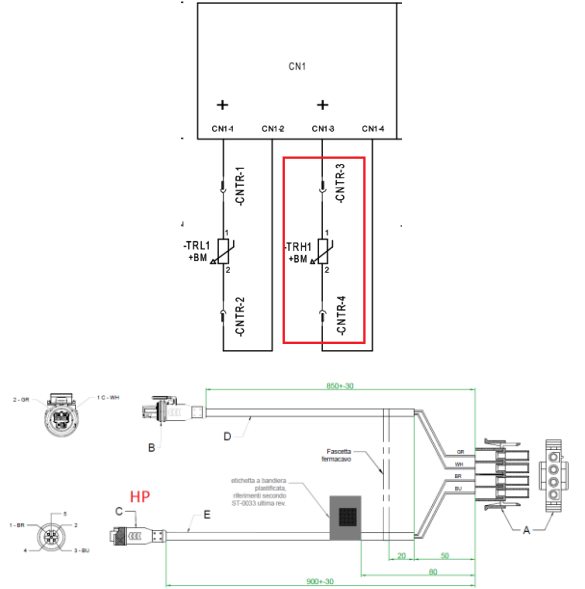
Code	Description	Block	Cause	What to check	What to do
E701	High pressure transducer failure		Transducer connected to ST10 input not connected or faulty	<ul style="list-style-type: none"> Check that the HP1 transducer is connected to connector 7 at pins 3 and 4 	<ul style="list-style-type: none"> If the connector is properly connected, the transducer may be defective. Replace with a new No. 7 connector

i-290 0121-0127 TROUBLESHOOTING

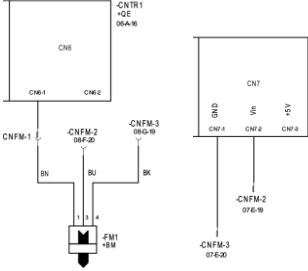
Code	Description	Block	Cause	What to check	What to do
E711	Flow meter fault (ratiometric analog input)	PUMP	FM1 Flow Meter Connected to Connector No. 5 Not Connected or Faulty	<ul style="list-style-type: none"> • Check the integrity of the cable connected between connector no. 5 and the FM1 flowmeter • Check that the connection inside the panel, between connector n°5 and CN6, CN7 of the control complies with the wiring diagram:  <ul style="list-style-type: none"> • Check that the flowmeter is working 	<ul style="list-style-type: none"> • If the cable connected between connector no. 5 and FM1 flowmeter is not intact, replace it • If the connection inside the panel, between connector n°5 and CN6, CN7 of the control is not at the wiring diagram, fix it • If the above points are verified, replace the flow meter

Code	Description	Block	Cause	What to check	What to do
E801 (*)	Inverter/control board communication timeout		<ul style="list-style-type: none"> • The compressor has not responded to control for more than 30 seconds. • The communication cable between the controller and the inverter is not connected or is defective 	<ul style="list-style-type: none"> • Check the communication cable between CNTR1 control CN15 connector and INV1 inverter: 	<ul style="list-style-type: none"> • Replace the wiring harness between CNTR1 and INV1 • If the error persists, replace the CNTR1 control board • If the error persists, replace the INV1 compressor driver

i-290 0121-0127 TROUBLESHOOTING

Code	Description	Block	Cause	What to check	What to do						
E851 (*)	Inverter Hardware Problem		Inverter or compressor failed. Incorrect connection between inverter and compressor	<ul style="list-style-type: none"> Check the continuity of the connection between the U, V and W of the inverter and the U, V, W of the compressor. <p>Replace the driver. Check the impedance between compressor phases:</p> <table border="1" data-bbox="904 328 1350 467"> <thead> <tr> <th data-bbox="913 336 1055 360">Model and size</th> <th data-bbox="1072 336 1267 360">Coil resistance at 20°C</th> </tr> </thead> <tbody> <tr> <td data-bbox="913 384 1010 408">0121-0123</td> <td data-bbox="1072 384 1144 408">0,299 Ω</td> </tr> <tr> <td data-bbox="913 424 1010 448">0125-0127</td> <td data-bbox="1072 424 1144 448">0,177 Ω</td> </tr> </tbody> </table> <p>If it deviates from the previous values, replace the compressor.</p>	Model and size	Coil resistance at 20°C	0121-0123	0,299 Ω	0125-0127	0,177 Ω	
Model and size	Coil resistance at 20°C										
0121-0123	0,299 Ω										
0125-0127	0,177 Ω										

i-290 0121-0127 TROUBLESHOOTING

(*) Inverter errors:

ERROR CODE DISPLAYED ON THE CONTROL	Number of flashes - Error description	Causes	Solutions
E821	IPM Overcurrent	Damaged IPM module	Change inverter
E831	PFC module overheating	Damaged PFC module	Change inverter
E841	DC undervoltage error DC Overvoltage Error (HW/SW)	Damaged inverter	Change inverter
E 851	Starting error		Change inverter
E 861	AC overcurrent protection		Change inverter
E 871	IPM module high temperature protection	Faulty IPM module	Change inverter
E 881	Overvoltage	Supply voltage too high	
	Supply voltage too low	Supply voltage too low	
E 891	Lack of feeding phases	One or more inverter power phases are not connected	Check the wiring of the inverter power phases

i-290 0121-0127 TROUBLESHOOTING

	Power Phase Problem (Software)	Faulty inverter	Change inverter
E 911	Compressor over-current protection	The compressor rotor is blocked	Replace the compressor
E 921	Over-current protectionPFC module	Faulty inverter	Change inverter
E 941	PFC Module Temperature Sensor Error	Faulty inverter	Change inverter
E 951	IPM Module Temperature Sensor Error	Faulty inverter	Change inverter
E 961	Abnormal Operation AD Module	Faulty inverter	Change inverter
	Compressor power supply phase failure	One or more compressor supply phases are not connected	Check the wiring of the compressor power phases
	Compressor speed error	Faulty inverter	Change inverter
	MCU Module Error	Faulty inverter	Change inverter
E 971	EEPROM Error	EEPROM Faulty	Replace the inverter
E 981	High pressure	Open STO Input	Check the pressure measured by the transducer of High pressure